

The M-A-C

The Newsletter of the EACC

Number Eighty Eight June 2025



Welcome to the June 2025 Issue of the MAC. My name is Alan Wilkins, but everyone calls me Al. This is the fourth edition of the Mac that I've edited and I'm still learning as I go so, please bear with me as I climb the learning curve.

This is your club magazine, so please help me fill future editions of the MAC by sending in your stories, articles, and events, that you would like to share with other members. I have set up an email address where you can send them in: maceditor@yahoo.com

Club Information

The EACC is the club for all Cyclemotor, Autocycle and Moped enthusiasts everywhere.

Membership forms are available from our website... or just ask and we'll send you one. Details of membership fees can be found on Page 3

Secretary: Andrew Roddham, 10 Gracious Street, Whittlesey, Peterborough, PE7 1AP.

Email: arodddham.eacc@btinternet.com

Telephone: 01733 703655

Membership & Webmaster: Andrew Pattle, 7 Unity Road, Stowmarket, Suffolk, IP14 1AS.

Email: membership@autocycle.org.uk

Telephone: 01449 673943

Dating Certificates & V765 Applications: Andrew Roddham:

arodddham.eacc@btinternet.com 01733-703655

Mark Daniels: mark.daniels975@btinternet.com 01473-716817

Treasurer: Sharon Wikner, 54 Dane Road, Warlingham, Surrey, CR6 9NP.

Email: sharonjwikner@gmail.com

EACC Committee Members: Andrew Roddham (Secretary), Sharon Wikner (Treasurer), Mark Daniels (Events Secretary), Martin Gates, Garth Jeffery, & Neil Morley, Andrew Pattle. Contact details for all officers are on the club information sheet, which is supplied when joining or renewing membership. Spare copies are available from the website or from the Secretary.

Events Secretary: Mark Daniels: mark.daniels975@btinternet.com 01473-716817

Club Publicity: Roxana Husain.

Club Regalia: Garth Jeffrey: growler.jeffrey@gmail.com 01508-499794

The MAC Magazine - the Club's Newsletter: Alan Wilkins Email: maceditor@yahoo.com

On-Line:

Website: www.autocycle.org.uk

Forum: <http://eacc.freeforums.net/>

Facebook: <https://www.facebook.com/groups/254351421715768/>

Icenicam: <http://www.icenicam.org.uk>

The Moped Archive: <http://www.users.globalnet.co.uk/~pattle/nacc/arcindex.htm>

FBHVC: <https://www.fbhvc.co.uk/>

The Moped Gallery: <https://www.icenicam.org.uk/gallery/galindex.html>

MEMBERSHIP FEES

Postal membership: £10.00 per annum via bank transfer or £10.60 via PayPal

Email membership: £4.00 per annum via bank transfer or £4.45 via PayPal

Application forms are available on the Website or please ask the Secretary to send you one, his address is above.

BIKE REGISTRATION & DATING CERTIFICATES

£15.00 per bike via bank transfer or £15.80 via PayPal

Re-issued certificates are £6.00 via bank transfer or £6.50 via PayPal

BANK DETAILS

Name: East Anglian Cyclemotor Club,

Sort Code: 30-93-22. **Account Number:** 00848165.

If you prefer to pay by cheque, please make it payable to the East Anglian Cyclemotor Club, make sure it's signed and then send it to the Membership Secretary. Please note that cheques sent to the Secretary may result in a delay whilst he passes them over to the Membership Secretary.

Sections

There are several regional Sections that organise events in their areas:

Essex: Paul Efreme has resigned, no replacement yet.

Hertfordshire: Andy Cousins, 01462 643564 Or 07969 369062

Lancashire Slow Riders: Paul Morgan, moggie64@gmail.com

Northamptonshire: Ray Paice, 07799 662203, raypaice@aol.com

Norfolk:

North East: Ron Paterson, ronpaterson21@gmail.com

South East Moped Enthusiasts: Sharon Wikner, 07771 705627,
sharonjwikner@gmail.com

Suffolk: Neil Morley, neil.morley@btinternet.com

Mark Daniels, 01473 716817, mark.daniels975@btinternet.com

Wiltshire: Steve Hoffman, 07891 251118, shffm@sky.com

Yorkshire: ('The Rotherham Roamers'): John Bann, 01709 961434,
mobymagic@gmail.com

If members in areas different from the ones listed above would like to start a new Section, please contact the Secretary. He will be pleased to hear from you and provide help to enable a new Section to be created.

Ray Paice (see above) did get a 'Midshires Group' going some time ago. There were 17 at the first meeting, then it gradually dwindled to just 5 people. It still meets once a month for lunch, but really needs more participants. If you are tempted to join the Group, please get in touch with Ray.

MAC Newsletter

For any articles, pictures, meetings or upcoming events please forward them to the Alan Wilkins "Al": maceditor@yahoo.com

Events

Every Tuesday: EACC Suffolk Section, members can be found at the Falcon, Walton, Felixstowe late on Tuesday evenings. See page 13 for forthcoming events

Every Month: EACC Lancashire Slow Riders gather on a Sunday morning from 10:30–12:00, once a month at the British Commercial Vehicle Museum, King Street, Leyland, PR25 2LE. There's no set date; it will be posted on the Slow Riders Facebook page. <https://www.facebook.com/groups/1117088391648578/> or enquire by e-mail: lancashireslowriders@gmail.com.

LSL have a few ride weekends planned already for 2024, all include camping at cheap rates or free....

Plenty more to follow, usually at least one a month between April-September
Check our Facebook page or email us (see details above) for up-to-date details.

Second Wednesday each month: EACC Norfolk Section meeting at The Bluebell, Bacton Road, North Walsham, NR28 0RA starting at 7pm.

South East Moped Enthusiasts (S.E.M.E) Run Calendar

For any further information call or text Sharon on 07771 705628 (or text)

Email: sharonjwikner@gmail.com

Moped Misfits Three Counties Meanders: Croperdy area, North Oxfordshire
Several outings planned, including trip to see a Vulcan Bomber, Gilkes cafe at Kineton and Hook Norton Brewery plus a camping weekend.

Email: judithrussellbrookes@hotmail.com

The Periwinkle Run aka The Pete Smith Memorial Run.

10th August, Cottered Village Hall SG9 9QR tea and coffee available. Meet at 10 onwards and set off at just after 11, stopping at The Beehive pub SG9 OBX for buffet lunch (small charge) then returning the hall for a raffle.

We also have the facility to accommodate an auto jumble / spares stall in the hall with notice.

All bikes are welcome, and breakdown support is supplied.

EACC Stand Invitation, National Horseracing Museum Newmarket, 14th June 2025

Alice Sophia is a Sales and Events Executive at the National Horseracing Museum in Newmarket. She emailed me asking about the possibility of an EACC display stand at their forthcoming Classic Car Show on Saturday 14th June 2025 which runs from 10am to 4pm. This is the second year the show has taken place. After an exchange of emails, I visited the site on 7th March to survey the proposed area and visit the museum.

The event is sponsored by Prestige Cars. So far, the Porsche Club GB, Norfolk & Norwich Rover Owners Club, MX-5 OWNERS CLUB, The East Anglian Practical Classics Club, and Triumph Stag Owners Club have signed up.

The organisers are looking for something different to augment the classic car display. A paddock marked X in the image below is provisionally allocated for an EACC display. There is limited parking opposite the paddock. This is normally reserved for museum staff but an exception can be made for EACC members on the day. The museum can also arrange a couple of standard sized gazebos for our display.

There is a participation fee of £10 for the day per exhibitor (individual). This allows full access to the museum, well worth a visit in my opinion. Participants will be given two wrist bands on arrival covering museum access as well as the classic car show.



The venue entrance is via Vicarage Rd, Newmarket, CB8 8HP on the right hand side of the image above. The entrance gates are opposite a SPAR shop and controlled via a gate code. Codes for gate access will be issued prior to the event.

The car show opens to the public from 10am to 4pm. Each club will be given an individual time slot for entry and set-up. Entry for set-up will start from 8am. The museum has a cafe and there are other venues nearby in Newmarket. Participants are kindly asked to not leave the site (in their vehicles) before 4pm. Vehicles may appear on the National Horseracing Museum website and social media accounts.

I've just returned from my travels for the past a couple of weeks. Mark and I received the invitation (details below and attached) from the National Horseracing Museum for the EACC to attend their classic car show on Saturday June 14th. Mark confirmed he's not available. I am available on the day but don't have a vehicle suitable for transporting my James Superlux.

Is it worthwhile asking the wider committee and membership to gauge the level of interest? Do we may have any members in the vicinity of Newmarket?

I will reply to Alice Sophie thanking her for the invitation explaining I'll forward it to the Committee and let her know the outcome.

Best regards,

Neil

Good afternoon, Neil and Mark,

I'm contacting you on behalf of the National Horseracing Museum in Newmarket. We are hosting a Classic Car Show on Saturday 14th June 2025 and I'm currently looking for exhibitors.

The site itself is 5 acres, and we have a mixture of paved and grass areas. The largest space in the grounds (for the show) is paved. I've attached a couple of images from last year and our sign-up form for your reference.

Is there any chance you might be able to advertise this event to your members? So far, we have the Porsche Club GB, Norfolk & Norwich Rover Owners Club, MX-5 OWNERS CLUB, The East Anglian Practical Classics Club, Triumph Stag Owners Club in attendance, and the event is sponsored by Prestige Cars.

It would be great if we could get your club involved- it would add something unique to the show. Although I appreciate the event is called 'Car Show' it would be interesting if we could organise a display with your club.

Thank you and hope to hear from you.

All the best
Alice

Alice Sophia | Sales and Events Executive | 01638 667314 ext. 138



NATIONAL HORSERACING MUSEUM



Bringing together
Legends & Classics

-CLASSIC CAR- SHOW

Saturday 14th June | 10am-4pm
at The National Horseracing Museum



SPONSORED BY

prestige

*Join us for a
different type of
horsepower*

WWW.NHRM.CO.UK

NHRM NATIONAL
HORSERACING
MUSEUM



CLASSIC CAR SHOW AT THE MUSEUM

Saturday 14th June 2025

Registration Form

Name:		
Email address:		
Phone Number:		
Car model:	Make:	Year:
Car Club:	Reg number:	
I am the owner of this vehicle:		
I have permission of the owner to display the vehicle:		
I confirm my car is roadworthy, covered by a valid MOT (if required by law) and by insurance. I agree to follow the instructions of the National Horseracing Museum staff whilst entering, within and on leaving the display area and to display my car until 4pm.		
Signed:		
Date:		

Participation fee: Please send completed forms to asophia@nhrm.co.uk - and your BACS £10 participation fee, quoting your name and registration number as a reference.

Account Name: Palace House Trading Ltd
Account Number: 63014541
Sort Code: 20-60-38

Address for entry: Vicarage Rd, Newmarket CB8 8HP – gates are opposite the shop SPAR and controlled via a gate code. Codes for gate access will be issued prior to the event.

Setup: The car show will be open to the public from 10am – 4pm. Each club will be given an individual time slot for entry and set-up. Entry for set-up will start from 8am. Participants are kindly asked to not leave the site (in their vehicles) before 4pm.

Museum Entry: Each participant will receive two wrist bands which will grant them full access to the museum.

Photographs: Cars may appear on the National Horseracing Museum website and social media accounts.

Sections

Suffolk Section notes – May 2025

13th April, EACC 20th Radar Run from Bromeswell village hall, with the AGM taking place before the run. A fine day for a ride, and a hugely popular event with some 45 bikes in attendance.

The only breakdown was an old Mobylette lost to a puncture at Shingle Street, but an incidental lift back to Bromeswell in a kind builders van solved the problem. Many folks chose to take lunch on the river veranda in the sunshine at Ramsholt Arms, which shows what a nice day it was, then went on to take the estuary views at Bawdsey Point. Thanks to all who attended.

Coming events:

29th June EACC Teenage Tantrum Run starting and finishing at Parham Airfield Museum as in the previous two years. Gather from 9:00am; the café and toilets should be available from 10am. The run to Sizewell for lunch will depart at 11:00 although the run may have a new lunch stop this year because of the huge upheavals at Sizewell. On return to the museum after lunch everyone can explore the excellent exhibits and café. Museum entry is free but donations to their funds are encouraged. Everyone welcome with free day membership if you're not an EACC member.

6th July EACC 22nd Peninsularis Run 21st from Suffolk Aviation Heritage Museum IP10 0AH. This is the site of the three big radio masts along Foxhall Road, on the left after Foxhall Stadium, as you head out of Ipswich towards Martlesham. A busy and atmospheric

day that is one of the major events on the cyclemotoring calendar; it features full reception facilities and free refreshments on arrival. There's no jumble but you're welcome to set up outside. Mopedland will be there with pre-ordered items only. The route is a superb course through the quiet countryside of the Felixstowe peninsula, including a superb 'riders section' between Nacton and Levington, a classic drag down a 'passing place' road to Trimley, lanes through to Falkenham, Kirton, the greenhouse village of Newbourne, then more lanes on to Waldringfield Maybush, an idyllic spot for lunch and ale in the sunshine. Return leg heads toward Matlesham, heads back towards Newbourne, through Brightwell, Bucklesham, and back to Foxhall. Some great fast-riding sections along the way. For information e-mail mark.daniels975@btinternet.com or tel: Mark Daniels on 01473-716817.

26th July David Silver Spares Bike meet in Leiston. 9.00am to 4.00pm. Free entry to the bike museum for the day, plus a catering and refreshment van on-site. More details on the East Anglian Cyclemotor Club Facebook page.

10th August 13th EACC Peter Smith Memorial Periwinkle Run from Cottered Village Hall, SG9 9QL. Meet from 10am, set off at 11am. A pub buffet lunch will be available. Also if anyone wants to set up a spares sale in the hall, that can be accommodated as well. For more details contact Paul Smith tel: 07811-952717. E-mail teampaulye@gmail.com

14th September Coprolite Run from Suffolk Aviation Heritage Museum IP10 0AH to Felixstowe Ferry

– more details later.

See you on the road ... Danny.

Hello, here is a little write up and some photos from Cropredy Moped Meander, event number 2025/11 , held over the May bank holiday weekend 2-5th May 2025.

Well, what a weekend, thank you everyone for taking the time to travel from all over the country to join us in Cropredy. A good-sized group of 12 bikes turned out over the weekend including several members of our family and local friends

Friday afternoon with everyone having arrived, we started off for a cracking little ride however, we'd hardly left the campsite before the first failure to proceed happened, a quick change of spark plug and off we went... Pat (a local friend) showed us round his very well stocked sheds, and all the items he had collected as a garage proprietor and historic rally car driver. Then off to a local Chinese takeaway where failure to proceed number 2 occurred, the SHA carburettor trick of sliding off the manifold happened, which was quickly corrected. The Food was chosen and a flotilla of hungry moped riders delivered said food back to the campsite where it was eagerly devoured.

Saturday started with a ride out to a local farming bygone museum, again another carburettor incident caused a slight delay. The volunteers kindly agreed to open especially for us, as the museum does not officially open until the end of May. Then on for lunch at Puddleduck farm cafe where there were more ancient, motorised paraphernalia including tractors, crawlers, ex war department recovery vehicles and even a 50cc pit bike cruiser for us to view.

After refuelling with food, we set off towards Fosseway Brewery, failure to proceed number 3, the end cap of an

exhaust fell off, but resourceful riders soon had it under control. We duly arrived at Fosseway Brewery, where Tony the Brewer entertained for longer than we thought possible. After this we travelled on for another few miles to our local pub, The Yew Tree Avon Dasset, which in the summer has an ice cream shack open in the garden, again the owner of the shack had kindly stayed behind to wait for us after her normal closing time so we could sample the most delicious ice cream we've ever tasted. After this everyone was ready for the short ride back to the camp site to sit and ponder on the day. Everything went well for a few miles, but those blasted potholes got the better of poor Jimmy and he managed to find a big one which caused a water bottle catastrophe, then George decided to bypass the turning towards the campsite, so we decided to take the not so scenic route back where unfortunately, an exhaust pipe decided it didn't want to go back to camp on its bike. Just as we arrived back at the campsite the lovely brewer turned up with some delicious beers and ciders for us all to drink, which we were happy to do whilst giving out awards for the weekend.

Sunday morning dawned cold and chilly a lot of extra layers required for the setting off. We dared to venture into the most pothole riddled county in the country, welcome to Northamptonshire. We all arrived at the depot at Weeden Bec, where there was plenty to see and eat. Unfortunately, one of us got there by pedalling. Ray our recovery, backstop, (amazing guy), recovered the poorly bike back to the campsite where it was packed away ready to be taken home and repaired. A fantastic weekend was had by all and we're all looking forward to the next gathering.

Richard and Judith













Lancashire Slow Riders



North Wales Tour

This has been an annual event for the past 4 years, it's planned the year before on dates that suit majority.

This year we only had 4 riders turn up, 1 all the way from Eastbourne, 1 from Northampton and another from County Durham, plus myself as the only representative from Lancashire section along with Martin who lives local.

Alot of planning and preparation goes into these organised weekends and without the support of local members, they now seem a waste of time, so it is with regret this will be the last event I plan to organise, hopefully someone else will step up and organise something in the future.

Back to the weekend, the weather wasn't the best, but we did a few rides.

Thursday we did a reccy run, Peter was using a Velosolex so we needed an idea of how it would perform on the Welsh countryside, it did extremely well, but Peter decided he would do his own routes and as he used to live in the area a long time ago, he was confident he could plan routes to suit his Velosolex.

Friday was supposed to be the best day, so we opted for the horseshoe pass-Llangollen -Carrock loop around 80 miles,

Peter/Velosolex set out an hour before the rest, myself c90, Terry ct125 and Dave Mobylette.

Within the first few miles Dave had a carb issue, first of a few all fixed at the roadside, but the Velosolex now had a good head start, we stopped around 6 miles before the climb up to the ponderosa above the horseshoe pass, and Peter rang to ask where we were, as he had been to the top and was now heading back down after completing the challenge.

We met Peter on the way, and he decided on an alternative route to what we were now taking on the horseshoe pass, so we carried on into Llangollen, then to Carrock station, which was shut and back to base.

Saturday- the plan was to attempt the Great Orme, no prob for the Hondas, but could prove a challenge for the Velosolex and the Mobylette, "it didn't" the Velosolex was first to the top with only a short head start, and it went up the steep side as there had been a rockfall on the slightly less steep part.

After the Great Orme we rode down in Conwy harbour for ice cream, giving the Solex a head start again and once again it was first to arrive. Maybe it didn't really need a head start.

After ice cream in the harbour, we got ready to set off again, the prom was crowded with people, but a space suddenly appeared after a loud explosion scattered them, the exhaust on the Moby had decided to depart on start up with such a bang! Dave quickly picked up the departed bits including the baffle and we made a sharp exit deafening people along the way, it was around 30 miles back to base and we had to listen to the loudest machine out on the roads all the way back, but the Moby did actually run better and faster than it had all weekend and made it back no prob .

We got back to base and for the first time all weekend we had beat the Velosolex for once.

Saturday evening, we decided to try out the local pub, what an eye opener and a great place. Dave the Moby certainly enjoyed it, that's for sure.

I'd like to thank the guys who travelled many miles to support this ride, it was very much appreciated by myself and Martin, hope you enjoyed it as much as I did, sorry the weather wasn't very good, but well done for taking part and completing the rides.

Signing off Paul Newton.









Couldn't make Stafford weekend, so made the most of the weather and took NH149 for a ride, Peter Moore on LRY and Frank bz on something with a triumph badge?

Called into the transport show at Leyland, John Yates was at Leyland Museum, along with (Dave Smith was there and a few other LSR,) then a gentle ride round the back roads to HESKIN HALL to support The Northwest Classic vehicles, we were greeted by Brian Crook, Tyree Norburn who was already there.

Took the long way back around some really good moped friendly back roads I'd never been on before, great day out riding the autocycles with good company, was really impressed with the Heskin Hall venue and will certainly be visiting again to their next event.

Paul Newton LSR





The Story of the Lost Pin by Sandy Ross

Readers of the EACC Newsletter will have read of my boyhood fascination with the launch of the then world beating Raleigh RM1 and RM2 mopeds, and that how many, many years later examples of both came to reside in my garage along with a motley collection of other little autocycles and 2 stroke motorcycles.

Each summer the bikes come out to play, the Raleigh's generally having been reliable over the years except for the usual HT coil failures. But last year the RM1C clutch failed to release resulting in much anguish and head scratching. The first RM1's were sold without a clutch; a combined throttle and decompressor allowing for a potentially difficult stop and start in traffic conditions. A conversion package was soon announced, and no doubt many bikes were subject to this rather complicated process which is set out in full in a works document available from the IcenicAM download library.

The RM1C clutch is rather basic and provides for very much of an 'In' or 'Out' operation. The mechanism is mounted to the nearside of the bottom bracket, which contains the Pedal shaft, driving shaft and Bottom Bracket Bearing Sleeve. (Items 37, 34 and 27). All these items are separated by needle roller bearings.

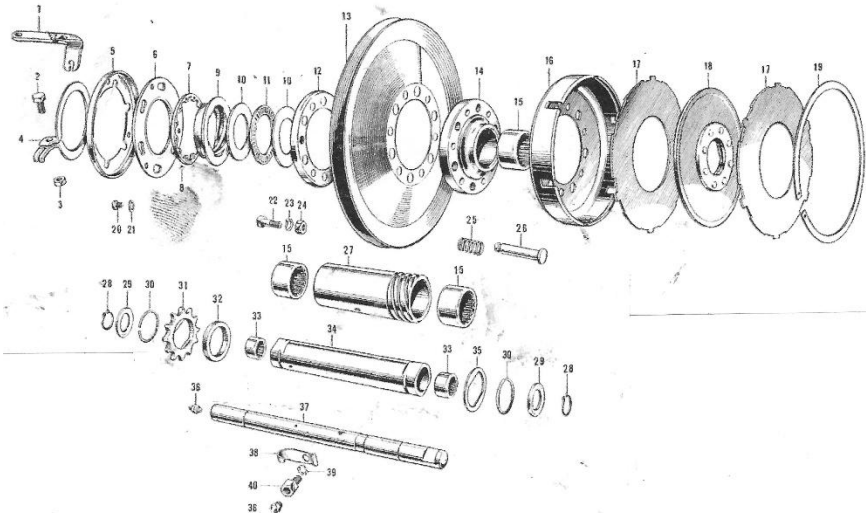

Returning home to the village a compulsory stop is required at an obscured junction, and much to my surprise on one of my regular journeys the clutch failed to disengage and a hasty stop by stalling was necessary. I assumed the clutch cable had broken, but an investigation proved that this was not the case, and the operating arm and release ring appeared to be working correctly.

I feared that something fatal had occurred within the mechanism, but what was the chance of obtaining any replacement parts? Nearly 20 years ago when I first purchased the RM1 some new parts were indeed still to be found, but supplies have dried up with the passage of time.

So, the RM1 was on the naughty step, the RM2 having to take over transport duties. Many sleepless nights later, suddenly an eureka moment as I tossed and turned in bed. The clutch plates are withdrawn by a Release Ring (Item 9), the very coarse thread of which engages with the threaded Bottom Bracket Bearing Sleeve and when rotated presses against the plates apart and so disengages the drive

Over the years I had conscientiously greased the bottom bracket roller bearing by a very obscure greaser hidden under the bracket by the silencer and Suresta stand – I cannot believe that many users of these bikes when new ever carried out this task! From my external observations I noted that the bottom bracket bearing sleeve was moving sideways slightly when the clutch lever was operated, so instead of the plates being withdrawn against the spring pressure the mechanism itself moved. I then turned the bike upside down, removed the exhaust system and suddenly it was obvious that the Location Pin, which includes the grease nipple, was missing. So, this pin, which I had greased so often, played a more important part than I had realised. I did retrace my journey several times in the hope of spotting the pin lying in the gutter, but this was a needle in a haystack endeavour.

The chances of finding a replacement seemed remote, and I did not want to remove that from the similar RM2 in case I could not realign the threaded hole in the sleeve so resulting in two RM's being out of action. I measured the depth of the hole for the pin and correctly

guessed that it would be a BSF thread. So, with a suitable screw fitted amazingly it correctly engaged with the sleeve and the clutch worked again! Since the pin is drilled and includes a grease nipple, I realised that the screw would have to be a short-term solution. I did contact some possible vendors of RM frames, which might still have the pin in place, but nobody was prepared to sell at a sensible price. But knowing the key dimensions, plus the general design from the parts list, my engineering friend manufactured an exact replacement. There was no problem in aligning the pin with the hole in the sleeve. The RM1C was back in full action!

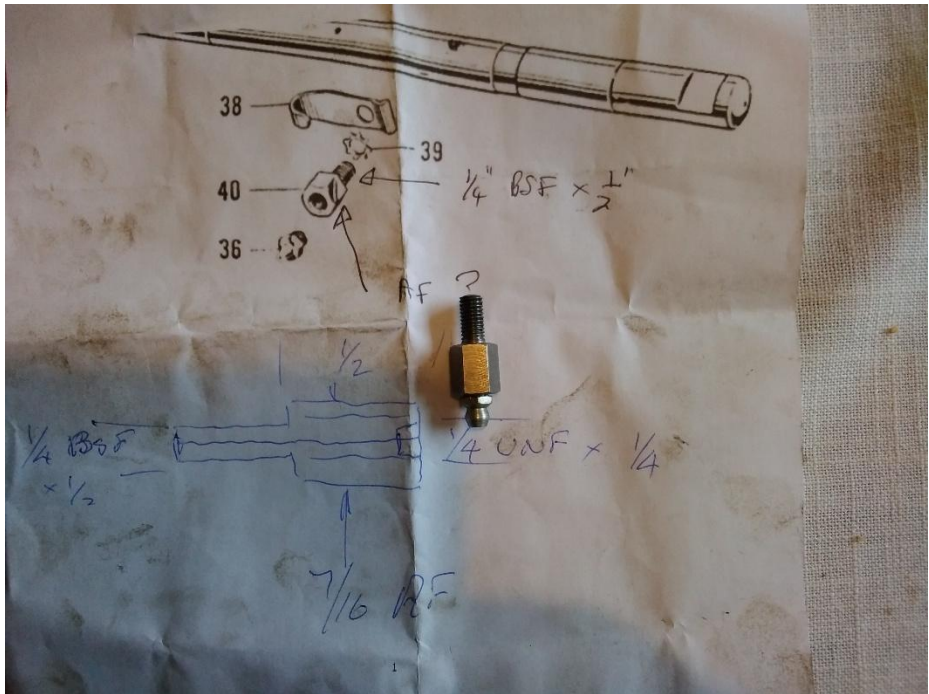

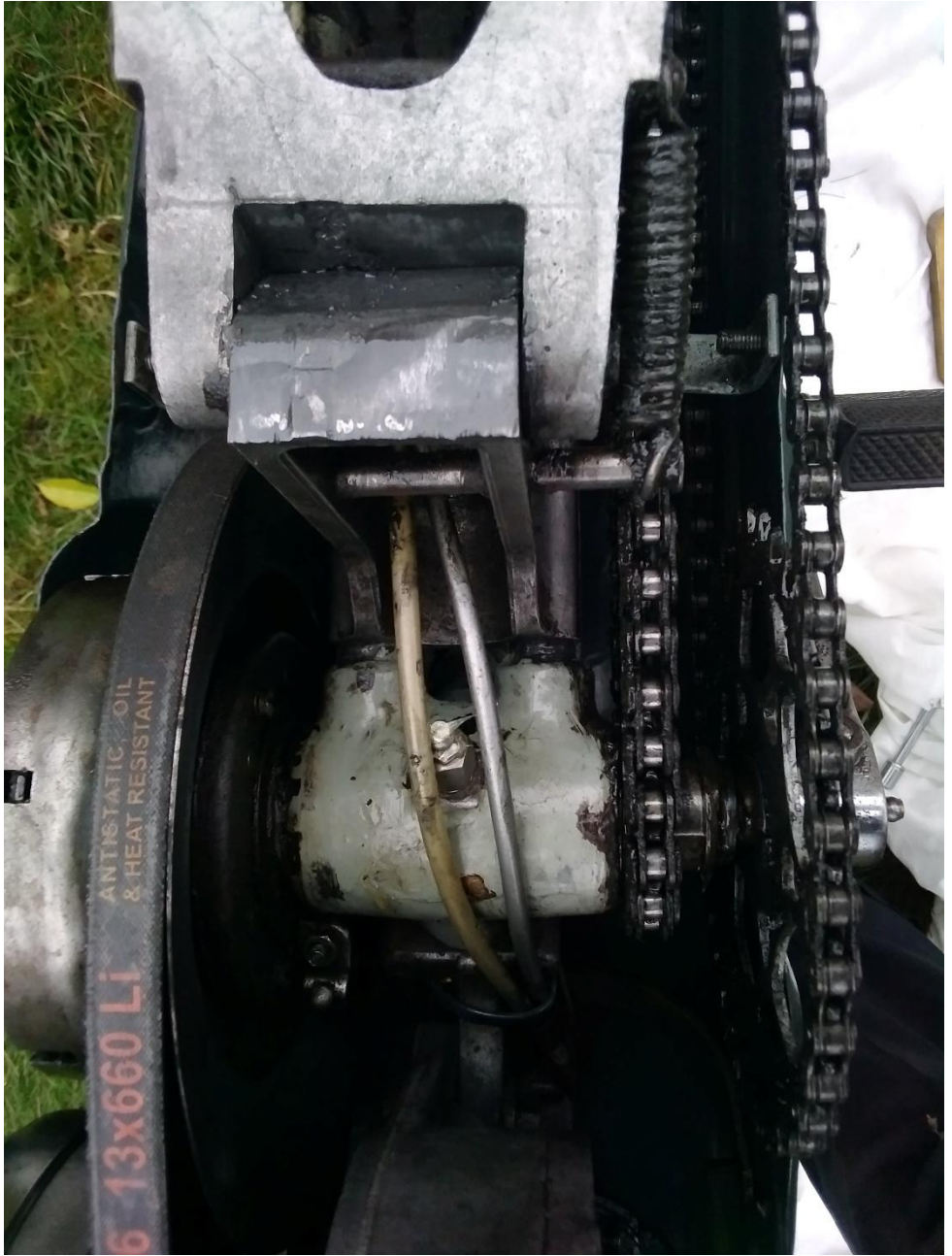



I have been a member for a few years now and live on the Somerset levels. Ideal for Solexes.

Left to right an Impex with 41mm Nicosil barrel and high compression Head giving it 54cc. Engineers report to convince DVLA. Sports silencer and upgraded main jet torque is way better than standard and top speed 25 mph.

Middle is 1977 3800 which came my way with good tyres and wheels but just about everything else needed, rebuilding. Same upgrades as Impex but standard capacity, top speed 23 mph.

Lastly is 1975 3800 which came my way in pieces and no documents. Armed with my EACC dating certificate from Andrew Roddham and advice from Nova and DVLA it went on the road 1st April.

It was sold new in Lorraine France when registration was not needed, and I acquired it from the son of the late owner who brought it over here 25 years ago and put in a cellar. Brian Solex advised on a complete engine rebuild and I must say you can't do that properly without a press and moderate heat for the main bearing change.

I wish there were some moped groups to ride with locally.

If any members are into classic car racing, they are welcome to contact me for a link to my Facebook page.

Best regards.

Reg.Palmer. reg.palmer@yahoo.com

Club Regalia : Contact – Garth Jeffrey. E-mail:
growler.jeffery@gmail.com

Tel: 01508-499794 Mobile: 07521-122213

Sew-on Badges, all £2.50p ea. White print on black background. *Illustrated*.

Red & Blue print on black background. Red & Blue print on white background.

Red & Blue print on silver background. *Illustrated*

Key rings £1 each *Illustrated

Small pin badge 1.½” (maroon) £2 ea. *Illustrated

Small EACC ‘Riders’ badge 1” (black/red) £2 ea.
*Illustrated

Large pin badge 1.½” (blue) £3 ea. *Illustrated

Stick-on badges (maroon) 2.½” diameter dome decal, fit on tax disc holder £2.50p ea. *Illustrated

T-shirts £7 ea. Sweatshirt Jumper £22 ea. Poloshirt £21 ea.
Fleece £26 ea.

New style high-vis £7.50p ea. Old style high-vis £7.50p ea.

